



UNIVERSITY OF CAMBRIDGE INTERNATIONAL EXAMINATIONS
International General Certificate of Secondary Education

CANDIDATE
NAME

CENTRE
NUMBER

--	--	--	--	--

CANDIDATE
NUMBER

--	--	--	--	--

* 8 2 5 1 5 5 6 8 6 9 *

CAMBRIDGE INTERNATIONAL MATHEMATICS

0607/04

Paper 4 (Extended)

October/November 2011

2 hours 15 minutes

Candidates answer on the Question Paper

Additional Materials: Geometrical Instruments
 Graphics Calculator

READ THESE INSTRUCTIONS FIRST

Write your Centre number, candidate number and name on all the work you hand in.

Write in dark blue or black pen.

Do not use staples, paper clips, highlighters, glue or correction fluid.

You may use a pencil for any diagrams or graphs.

DO NOT WRITE IN ANY BARCODES.

Answer **all** the questions.

Unless instructed otherwise, give your answers exactly or correct to three significant figures as appropriate.

Answers in degrees should be given to one decimal place.

For π , use your calculator value.

You must show all the relevant working to gain full marks and you will be given marks for correct methods, including sketches, even if your answer is incorrect.

The number of marks is given in brackets [] at the end of each question or part question.

The total number of marks for this paper is 120.

For Examiner's Use

--

This document consists of **18** printed pages and **2** blank pages.



Formula List

For the equation

$$ax^2 + bx + c = 0$$

$$x = \frac{-b \pm \sqrt{b^2 - 4ac}}{2a}$$

Curved surface area, A , of cylinder of radius r , height h .

$$A = 2\pi rh$$

Curved surface area, A , of cone of radius r , sloping edge l .

$$A = \pi rl$$

Curved surface area, A , of sphere of radius r .

$$A = 4\pi r^2$$

Volume, V , of pyramid, base area A , height h .

$$V = \frac{1}{3}Ah$$

Volume, V , of cylinder of radius r , height h .

$$V = \pi r^2 h$$

Volume, V , of cone of radius r , height h .

$$V = \frac{1}{3}\pi r^2 h$$

Volume, V , of sphere of radius r .

$$V = \frac{4}{3}\pi r^3$$

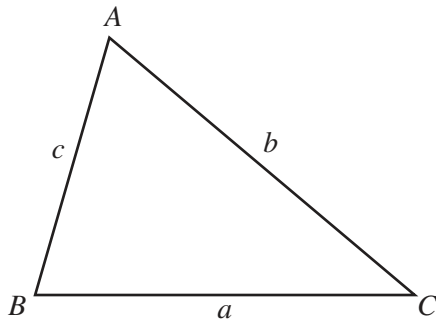

$$\frac{a}{\sin A} = \frac{b}{\sin B} = \frac{c}{\sin C}$$

$$a^2 = b^2 + c^2 - 2bc \cos A$$

$$\text{Area} = \frac{1}{2}bc \sin A$$

Answer **all** the questions.

For
Examiner's
Use

1 Alessandro travels from a village in France to his home in Italy.

(a) His flight from Paris to Rome takes 1 hour 57 minutes.

(i) The departure time is 1025.
Write down the arrival time.

Answer(a)(i) [1]

(ii) Write down the flight time in hours.

Answer(a)(ii) h [1]

(iii) The distance between Paris and Rome is 1120 km.

Calculate the average speed of the flight.
Give your answer in km/h.

Answer(a)(iii) km/h [2]

(b) The flight time of 1 hour 57 minutes is 26% of Alessandro's total journey time.

Calculate Alessandro's total journey time.
Give your answer in hours and minutes.

Answer(b) h min [3]

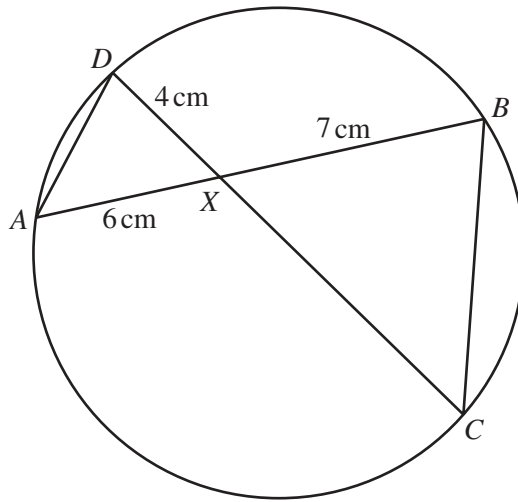

NOT TO
SCALE

In the circle, the chords AB and CD intersect at X .

(a) Complete the statement.

Angle ADX is equal to angle [1]

(b) $AX = 6$ cm, $DX = 4$ cm and $XB = 7$ cm.

Calculate the length of XC .

Answer(b) cm [2]

(c) The area of triangle BXC is 32.7 cm².

Calculate the area of triangle DXA .

Answer(c) cm² [2]

3 Maria invests \$480 at a rate of 2.6% per year compound interest.

(a) Calculate the interest Maria receives after 5 years.

Answer(a) \$ [4]

(b) Calculate the number of years it takes for the total amount to exceed \$800.
Show your working and give your answer to the nearest integer.

Answer(b) [3]

*For
Examiner's
Use*

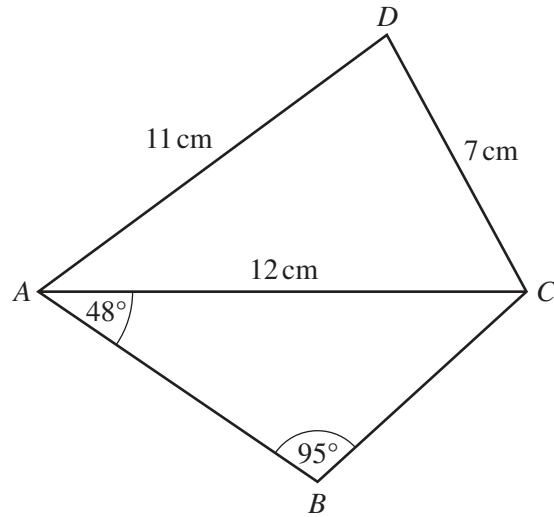
NOT TO
SCALE

In the quadrilateral $ABCD$, $AD = 11$ cm, $DC = 7$ cm and $AC = 12$ cm.

Angle $BAC = 48^\circ$ and angle $ABC = 95^\circ$.

(a) Calculate the length of BC .

Answer(a) cm [3]

(b) Calculate angle ADC .

Answer(b) [3]

5 $f(x) = 2x^2 - 3x - 3$

(a) Solve the equation $f(x) = 0$.

Give your answers correct to 2 decimal places.

Answer(a) $x =$ or $x =$ [3]

(b) $f(2x - 3) = 8x^2 - kx + 24$

Find the value of k .

Answer(b) $k =$ [3]

*For
Examiner's
Use*

6

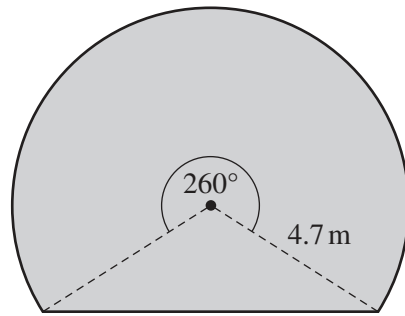
NOT TO
SCALEFor
Examiner's
Use

The diagram shows the cross-section of a tunnel.
This cross-section is made up of a triangle and a sector of radius 4.7 m and angle 260° .

(a) Calculate the area of the cross-section.

Answer(a) m² [5]

(b) The tunnel has a length of 2.4 km.

Calculate the volume of earth that was removed to make the tunnel.
Give your answer in cubic metres.

Answer(b) m³ [2]

(c) One cubic metre of earth has a mass of 1530 kg.

Calculate the total mass of the earth that was removed.
Give your answer in **tonnes** and correct to 2 significant figures.

For
Examiner's
Use

Answer(c) tonnes [3]

7

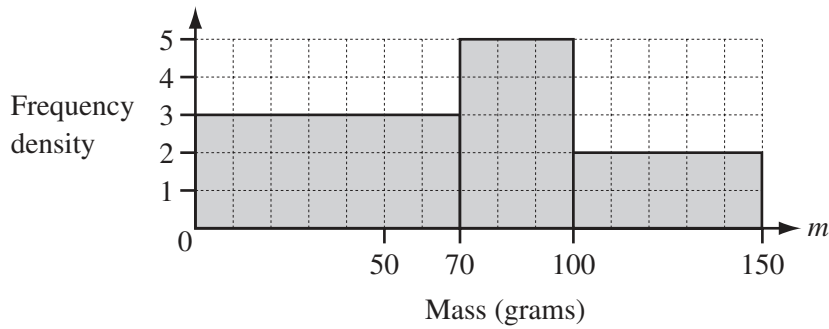

The histogram shows information about the masses of some apples.

(a) Complete the frequency table.

Mass (m grams)	$0 \leq m < 70$	$70 \leq m < 100$	$100 \leq m < 150$
Frequency	210		

[2]

(b) Calculate an estimate of the mean mass of the apples.

Answer(b) g [2]

8 In this question, answers which are not exact should be given correct to 4 significant figures.

For
Examiner's
Use

(a) $f(x) = x^4 - x^2$

(i) On the axes, sketch the graph of $y = f(x)$, for $-1.5 \leq x \leq 1.5$.

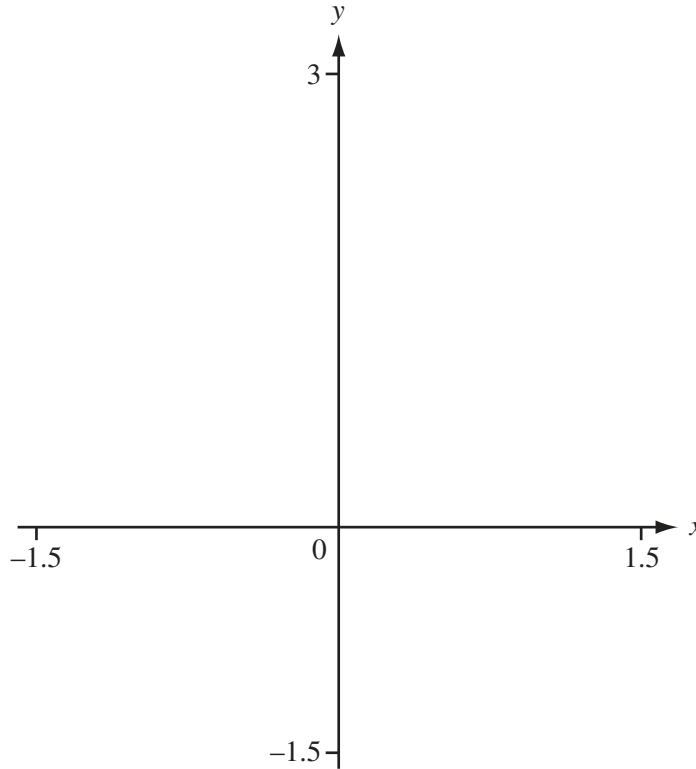

[2]

(ii) Write down the co-ordinates of the points where the graph meets the axes.

Answer(a)(ii) (..... ,), (..... ,), (..... ,) [2]

(iii) Write down the equation of the line of symmetry of this graph.

Answer(a)(iii) [1]

(iv) Find the co-ordinates of the minimum points.

Answer(a)(iv) (..... ,), (..... ,) [2]

(v) Write down the range of $f(x)$ when the domain is \mathbb{R} .

Answer(a)(v) [1]

(b) (i) On the axes, sketch the graph of $y = g(x)$, where $g(x) = 2^x - 1.6$. [2]

(ii) Solve the equation $2^x - 1.6 = 0$.

Answer(b)(ii) $x =$ [1]

(c) (i) Solve the equation $x^4 - x^2 = 2^x - 1.6$, for $-1.5 \leq x \leq 1.5$.

Answer(c)(i) $x =$ or $x =$ [2]

(ii) Solve the inequality $f(x) < g(x)$.

Answer(c)(ii) [1]

9

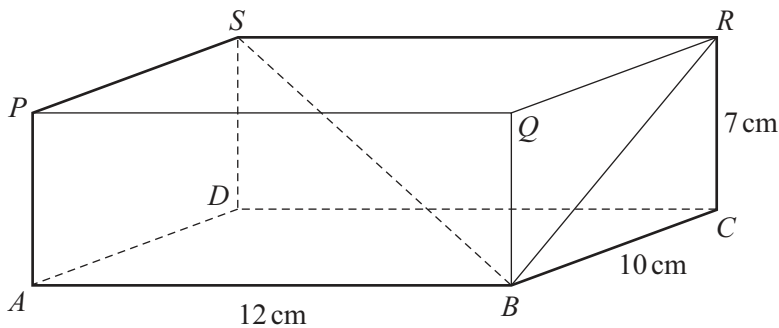

NOT TO SCALE

The diagram shows a cuboid which measures 12 cm by 10 cm by 7 cm.

(a) Calculate the total surface area of the cuboid.

Answer(a) cm^2 [2]

(b) Calculate angle RBC .

Answer(b) [2]

(c) Calculate the length BS .

Answer(c) cm [3]

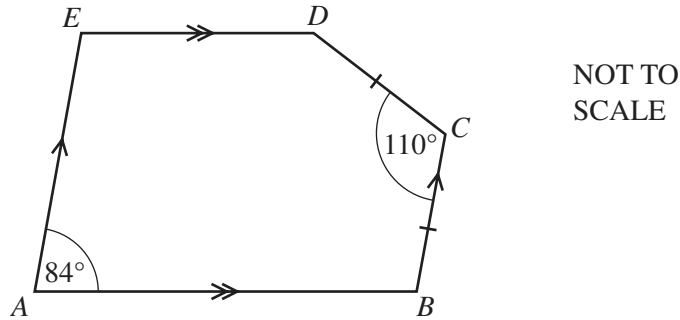

In the pentagon $ABCDE$, AB is parallel to ED , BC is parallel to AE and $BC = CD$.
Angle $EAB = 84^\circ$ and angle $BCD = 110^\circ$.

(a) (i) Find the size of angle AED .

Answer(a)(i) [1]

(ii) Find the size of angle CDE .

Answer(a)(ii) [2]

(b) Draw the line BD and find the size of angle ABD .

Answer(b) [2]

(c) Extend ED and BC to meet at X .

(i) Write down the mathematical name of the shape $ABXE$.

Answer(c)(i) [1]

(ii) Write down the size of angle CXD .

Answer(c)(ii) [1]

(d) Extend AB and DC to meet at Y .

(i) Find the size of angle BYC .

Answer(d)(i) [1]

(ii) Give a reason why it is **not** possible to draw a circle through B , Y , X and D .

Answer(d)(ii) [1]
.....

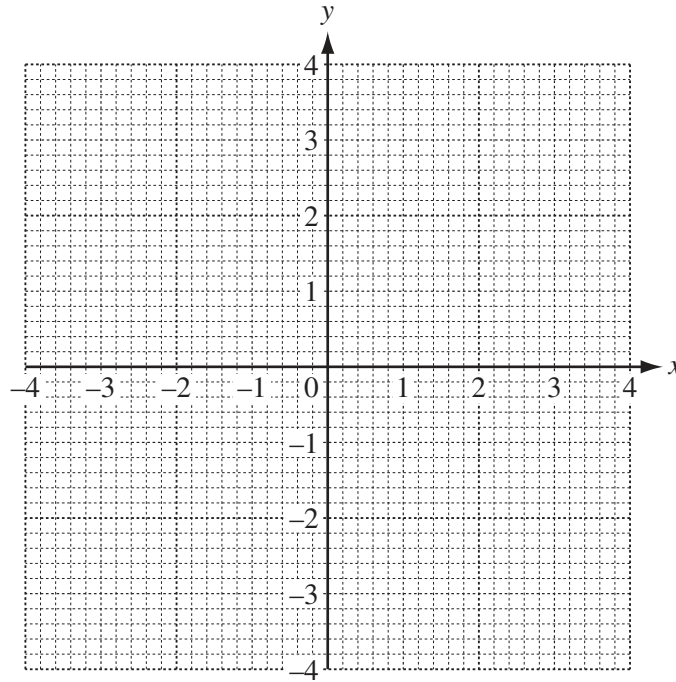

$f(x) = x^2$
 $g(x) = (x + 2)^2$
 $h(x) = 2x^2$
 $k(x) = -x^2$

(a) On the grid, sketch the graph of each function.
Label each graph clearly. [4]

(b) Describe fully the **single** transformation that maps

(i) the graph of $y = f(x)$ onto the graph of $y = g(x)$,

Answer(b)(i)

..... [2]

(ii) the graph of $y = f(x)$ onto the graph of $y = h(x)$,

Answer(b)(ii)

..... [3]

(iii) the graph of $y = f(x)$ onto the graph of $y = k(x)$.

Answer(b)(iii)

..... [2]

12 On any day, the probability that it rains is 0.15 .

If it rains, the probability that Claudia rides her bike is 0.3 .

If it does not rain, the probability that Claudia rides her bike is 0.9 .

(a) Draw a tree diagram to show this information.

Write the probabilities on all the branches.

[4]

(b) Find the probability that

(i) it does not rain and Claudia rides her bike,

Answer(b)(i) [2]

(ii) Claudia rides her bike.

Answer(b)(ii) [2]

(c) During a period of 15 days, on how many days would Claudia expect to ride her bike?

Answer(c) [1]

13

For
Examiner's
Use

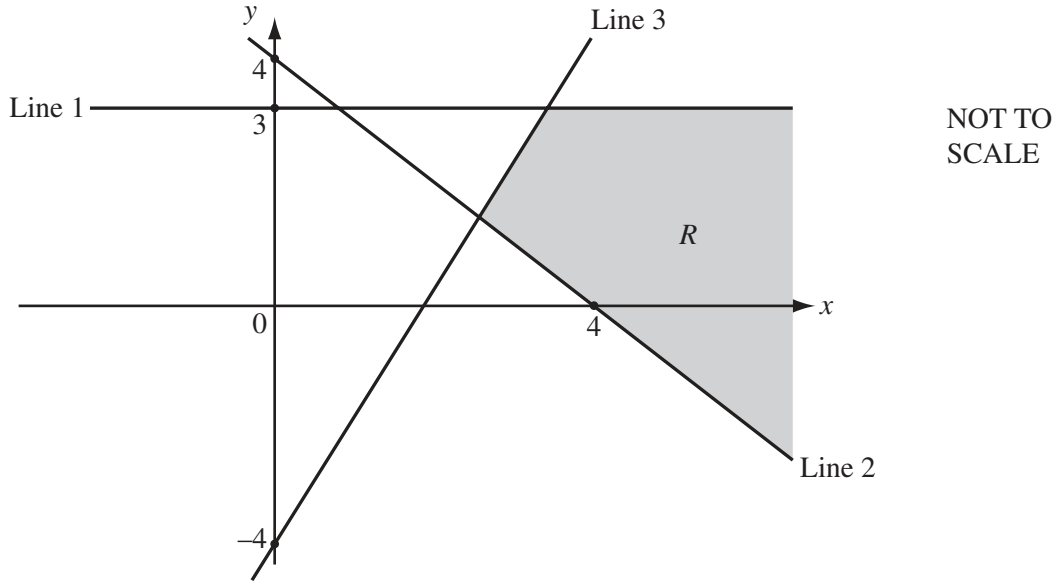

- (a) Line 1 is parallel to the x -axis and passes through the point $(0, 3)$.

Write down the equation of Line 1.

Answer(a) [1]

- (b) Line 2 passes through the points $(0, 4)$ and $(4, 0)$.

Find the equation of Line 2.

Answer(b) [2]

- (c) Line 3 passes through the point $(0, -4)$ and has a gradient of 2.

Write down the equation of Line 3.

Answer(c) [2]

- (d) Find the co-ordinates of the point of intersection of Line 2 and Line 3.

Answer(d) (..... ,) [2]

- (e) Write down the three inequalities that define the region R , shaded in the diagram.

Answer(e) , , [2]

- 14 Ten students take a mental arithmetic test and a calculator test.

The table shows the results.

Student	<i>A</i>	<i>B</i>	<i>C</i>	<i>D</i>	<i>E</i>	<i>F</i>	<i>G</i>	<i>H</i>	<i>I</i>	<i>J</i>
Mental arithmetic test score (x)	15	8	20	19	13	7	10	20	17	9
Calculator test score (y)	12	8	18	20	11	9	11	20	15	8

- (a) Complete the scatter diagram to show this information.

The information for students *A* to *F* has already been plotted.

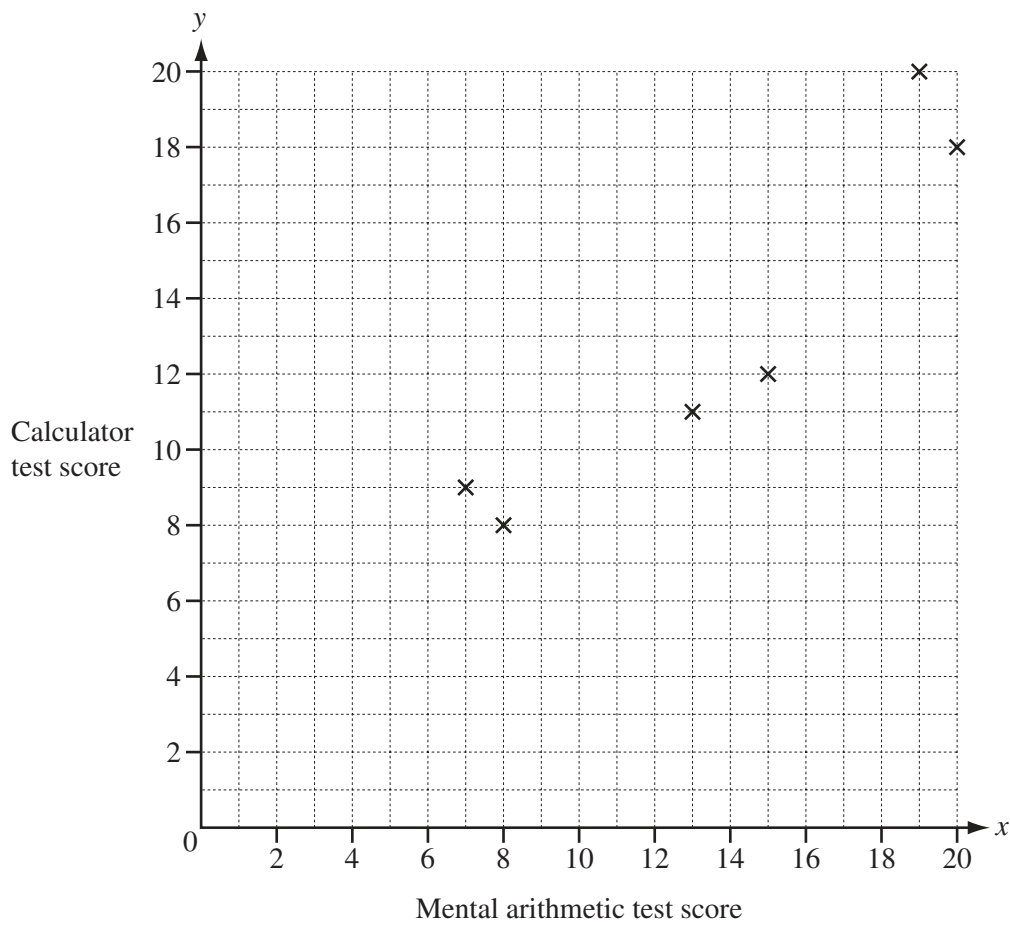

[2]

- (b) Underline one word which best describes the correlation between the scores on each test.

none

positive

negative

[1]

- (c) (i) The mean score for the mental arithmetic test is 13.8 .

Find the mean score for the calculator test.

Answer(c)(i) [1]

- (ii) Find the equation of the line of regression, giving y in terms of x .

Answer(c)(ii) $y =$ [2]

- (iii) Draw the line of regression on the scatter diagram. [2]

- (iv) A student scores 18 in the mental arithmetic test.

Predict this student's score in the calculator test.

Answer(c)(iv) [1]

*For
Examiner's
Use*

- 15 (a) (i) A circle is cut into n equal sectors.

Write down, in terms of n , the angle at the centre of each sector.

Answer(a)(i) [1]

- (ii) A circle is cut into $n + 3$ equal sectors.

Write down, in terms of n , the angle at the centre of each sector.

Answer(a)(ii) [1]

- (b) The angle in **part(a)(ii)** is 4° smaller than the angle in **part(a)(i)**.

Write down an equation in n and find the value of n .

Answer(b) $n =$ [5]

BLANK PAGE

Permission to reproduce items where third-party owned material protected by copyright is included has been sought and cleared where possible. Every reasonable effort has been made by the publisher (UCLES) to trace copyright holders, but if any items requiring clearance have unwittingly been included, the publisher will be pleased to make amends at the earliest possible opportunity.

University of Cambridge International Examinations is part of the Cambridge Assessment Group. Cambridge Assessment is the brand name of University of Cambridge Local Examinations Syndicate (UCLES), which is itself a department of the University of Cambridge.